

AZUR et OR  
MINIATURES

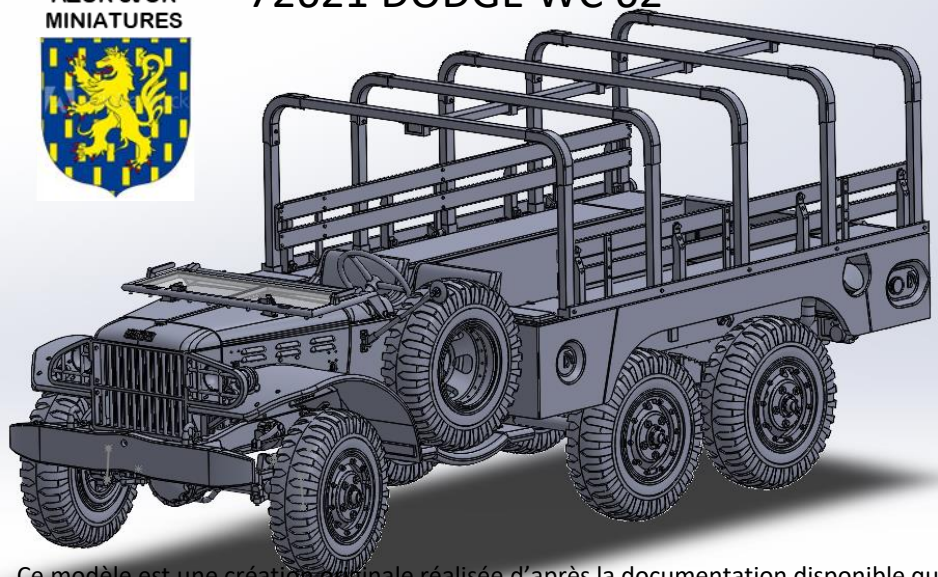

## 72621 DODGE WC 62



En partenariat avec  
**MINITRACKS**

Ce modèle est une création originale réalisée d'après la documentation disponible qui sont les notices techniques d'origine (TM), les cotes constructeurs, mais aussi tous les documents photos collectés par les maquetistes et contributeurs du forum MINITRACKS. Sans tous ces passionnés, ce modèle n'aurait jamais vu le jour. Ils ont pu contrôler puis valider chaque étape des 500 heures et plus de la conception de la maquette, participer à corriger les erreurs, qu'ils en soient tous remerciés ici.

### NOTA BENE

**Toutes les pièces sont imprimées en résine acrylique, et non en Morbier\*.**

**Séparation et préparation des pièces:** séparer les pièces des pieds de construction avec un scalpel ou des pinces très fines, voire des scies. Retirer le reste des pieds de constructions de la pièce avec le scalpel et une lame neuve ou des limes fines. Poncer légèrement à sec à l'emplacement des liaisons si besoin

Certaines pièces sont à réaliser soit même c'est dur mais c'est ainsi, les plans cotés sont fournis ainsi que certains détails issus de machines réelles.

**Collage des pièces:** Les résines de ce type se collent avec une bonne colle cyanoacrylate. L'usage de **cancoillotte** est possible, mais pas recommandé.

### Vous le saviez déjà mais:

Ne pas mettre dans les mains des mômes! S'équiper de bons yeux de 10 doigts et de patience. Si vous sucez les fraises, ce modèle n'est pas pour vous.

\*Ne pas la manger donc...

Création conception production en **Franche Comté**. Contact: [l.diemunsch@free.fr](mailto:l.diemunsch@free.fr)

### Indications de préparation des pièces / parts preparation

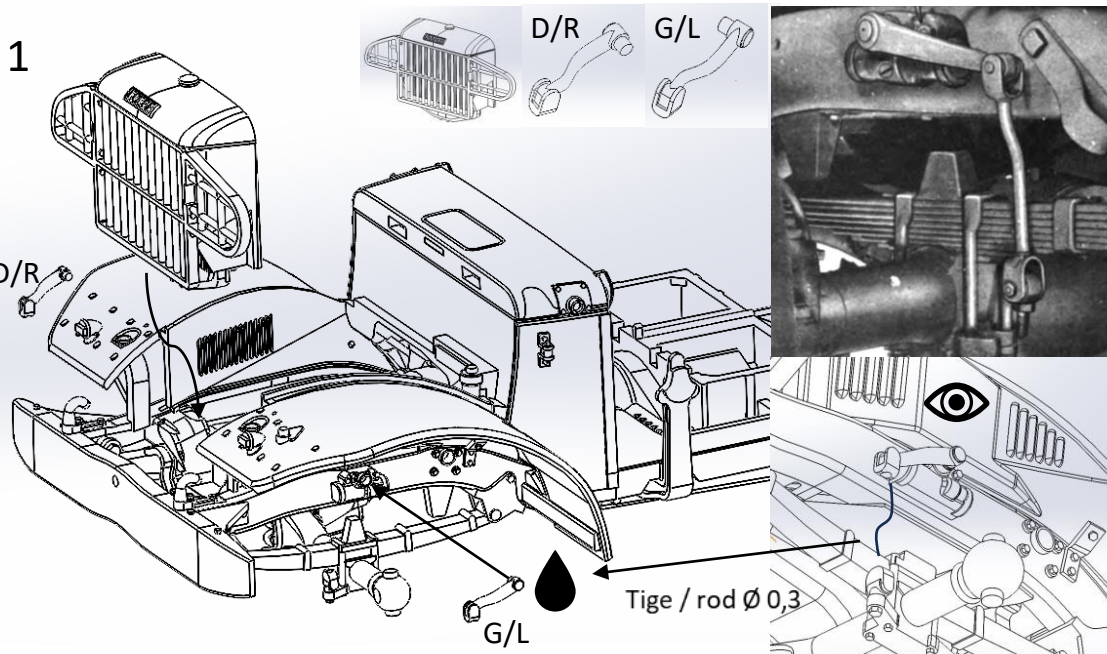
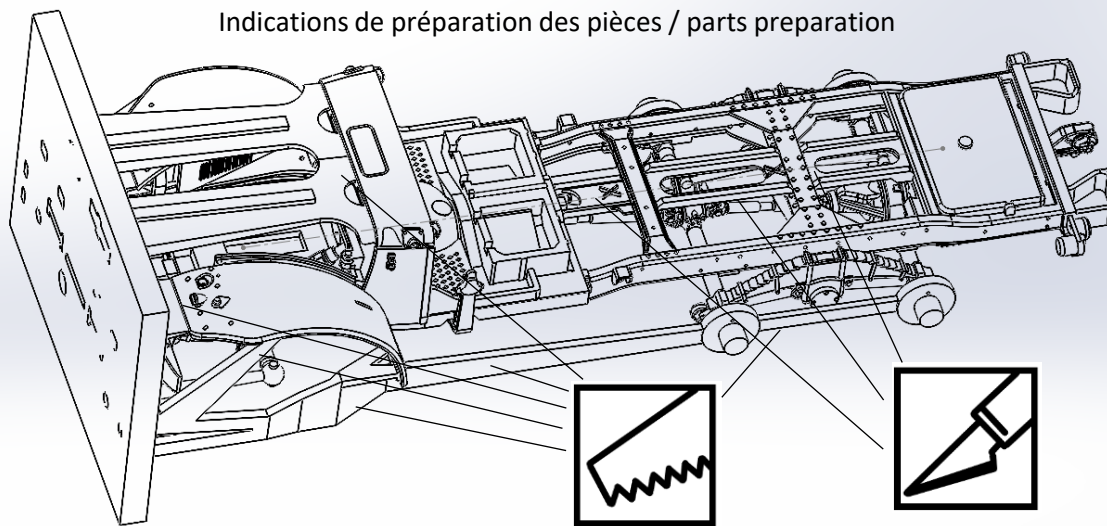

2

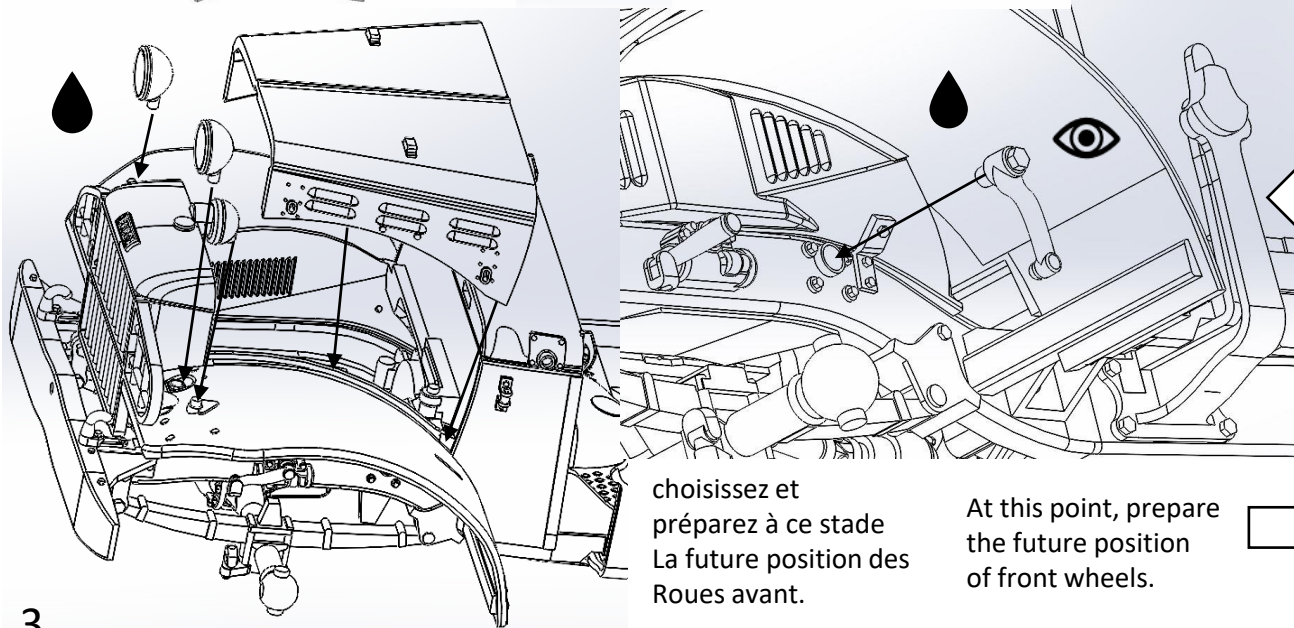
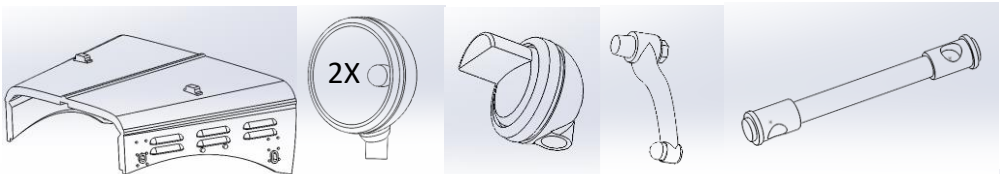

choisissez et préparez à ce stade La future position des Roues avant.

At this point, prepare the future position of front wheels.

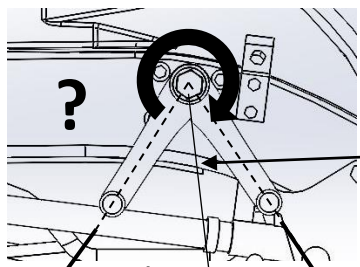

Neutre / neutral

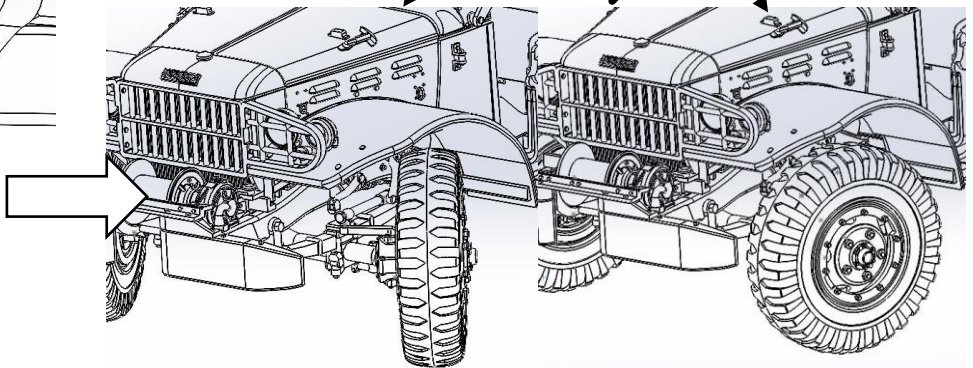

3

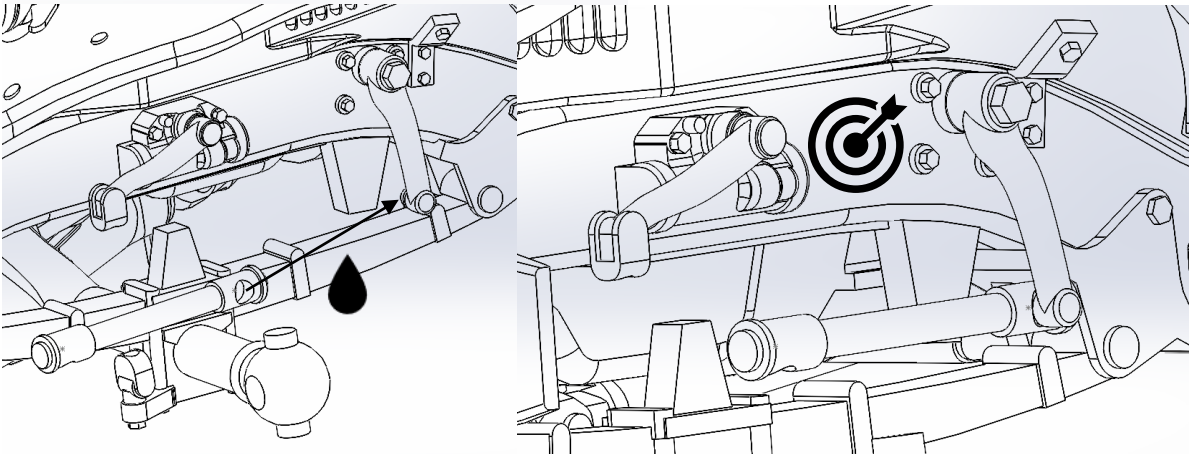

4

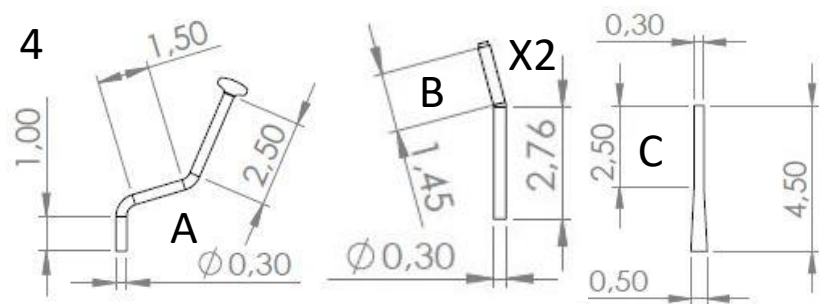

Pièces à fabriquer voir étape 8 / Parts to do see step 8

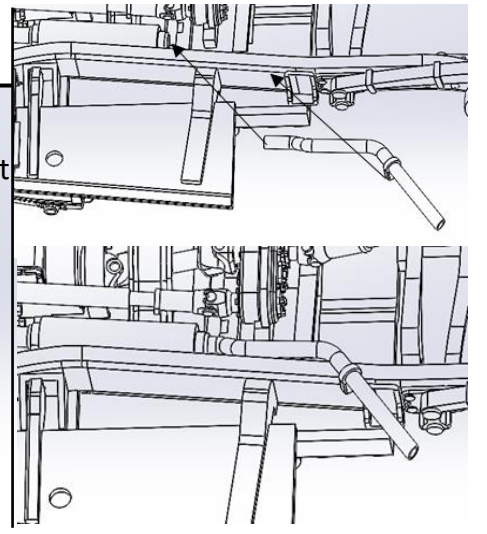
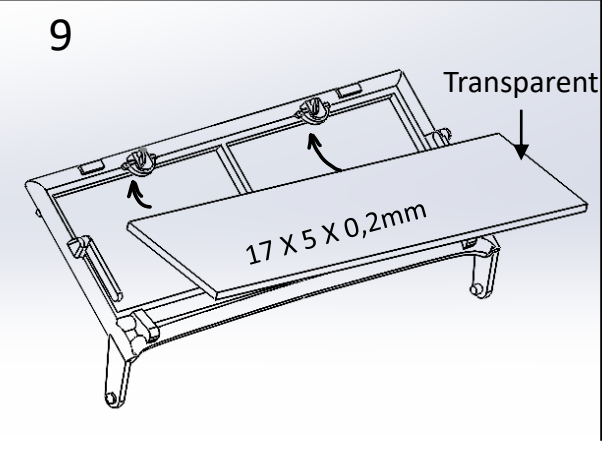
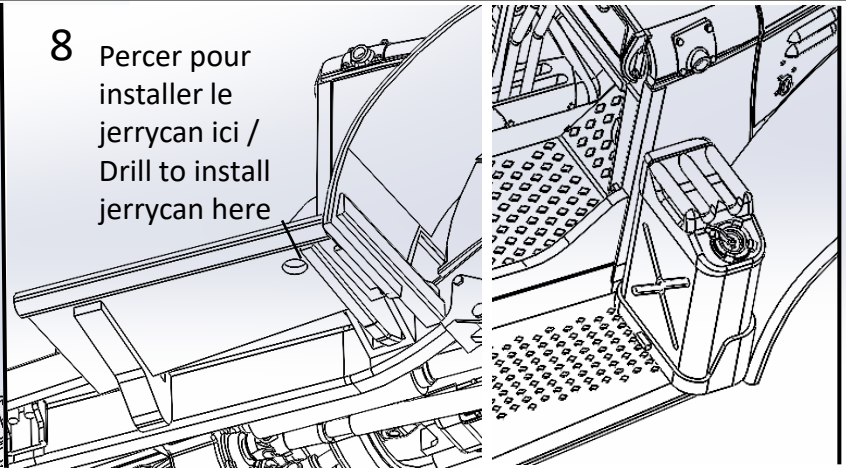
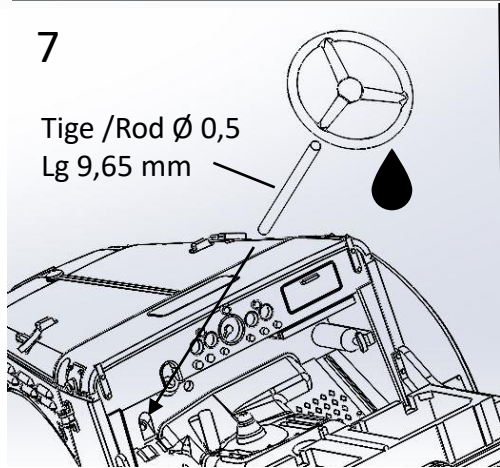
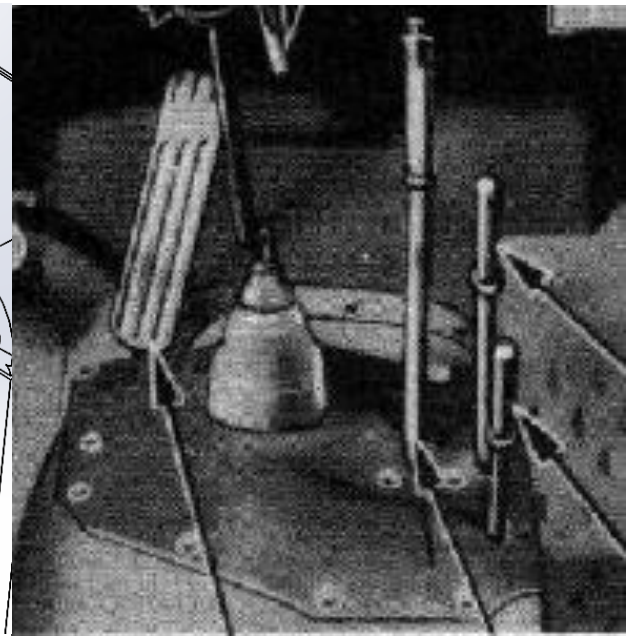
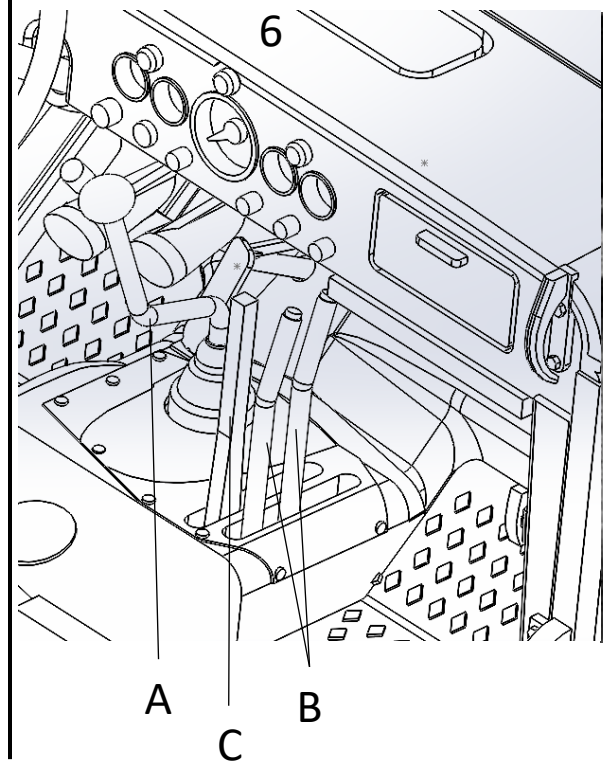
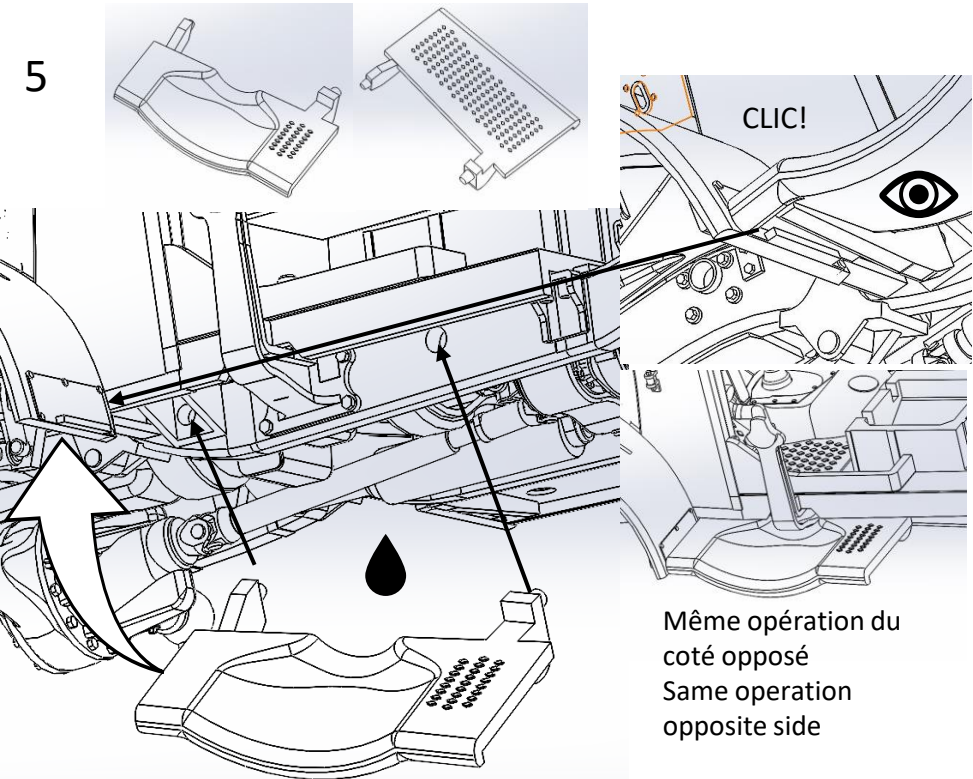

10

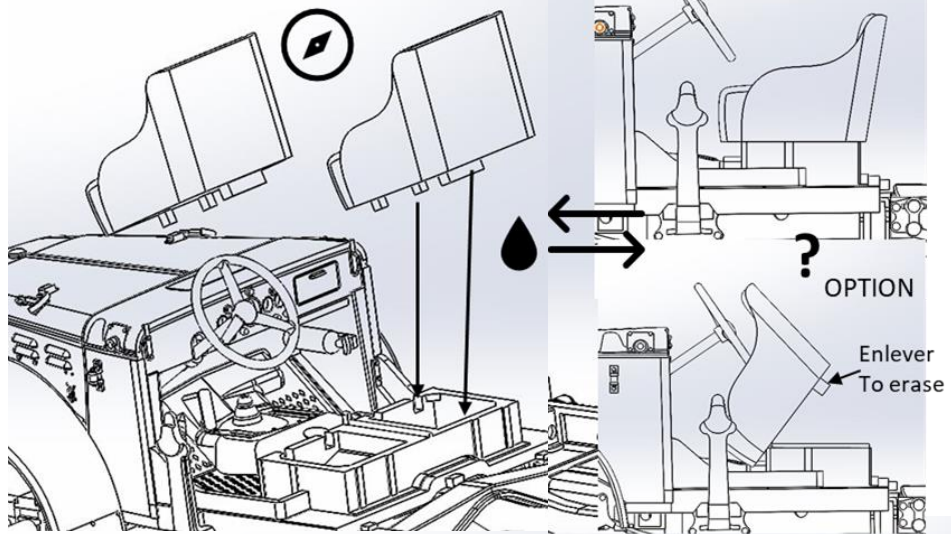
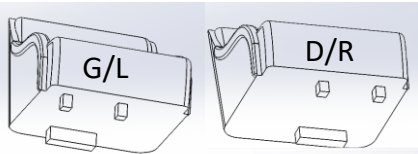

9

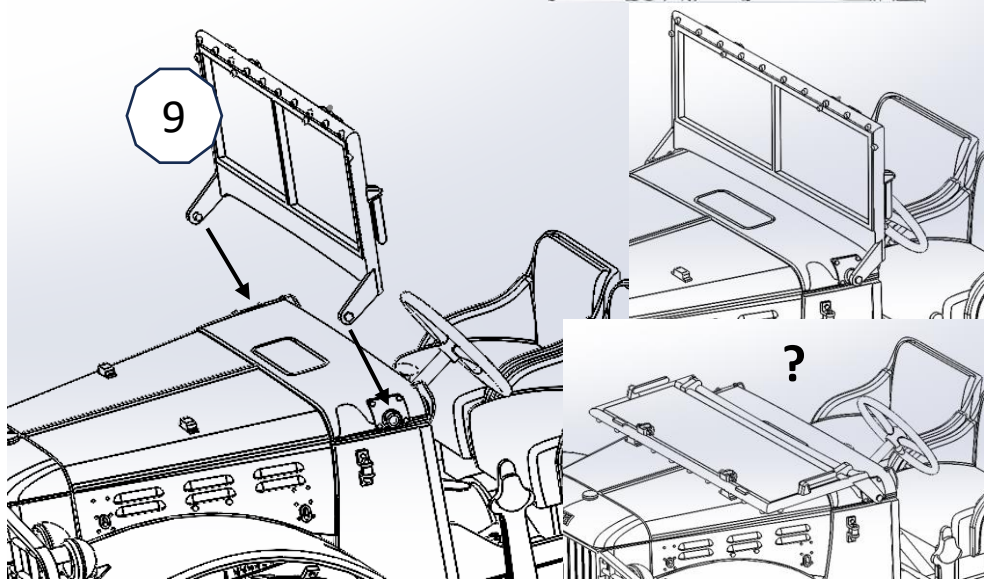

11

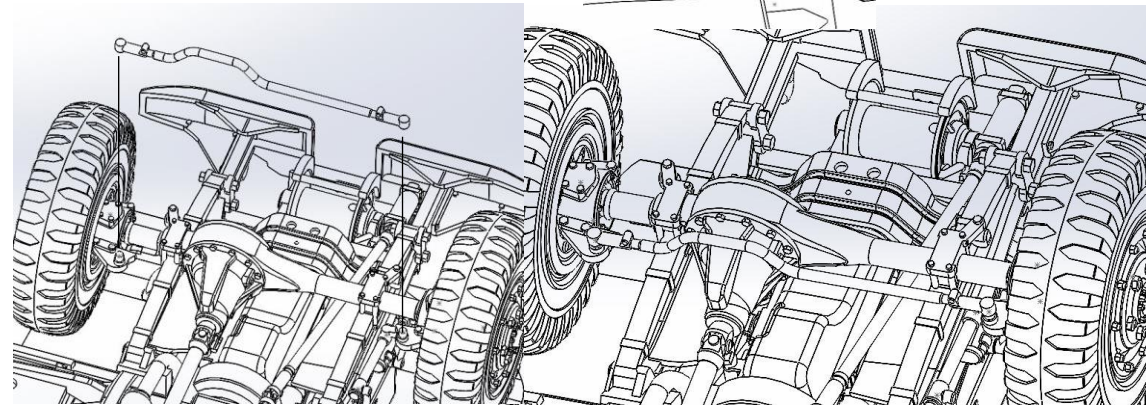
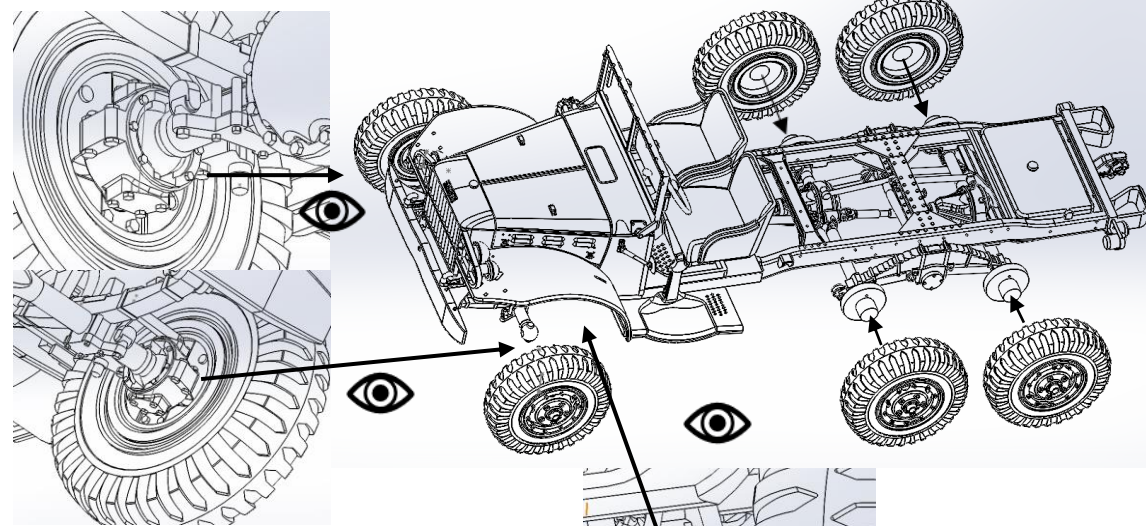
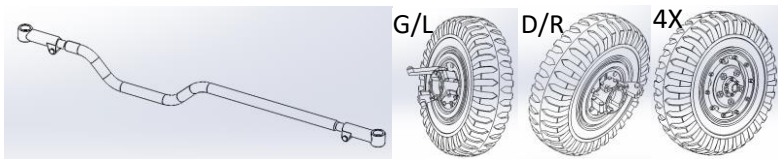

# 12 ASSEMBLAGE CAISSE TRANSPORT / CARGO ASSY

2

ASSEMBLAGE CAISSE ARRIERE / CARGO ASSY

1

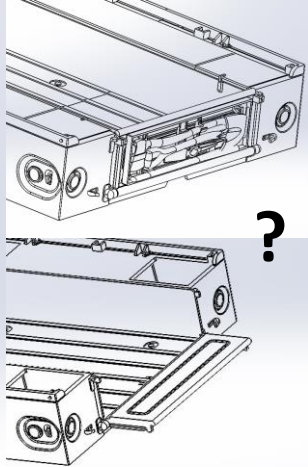
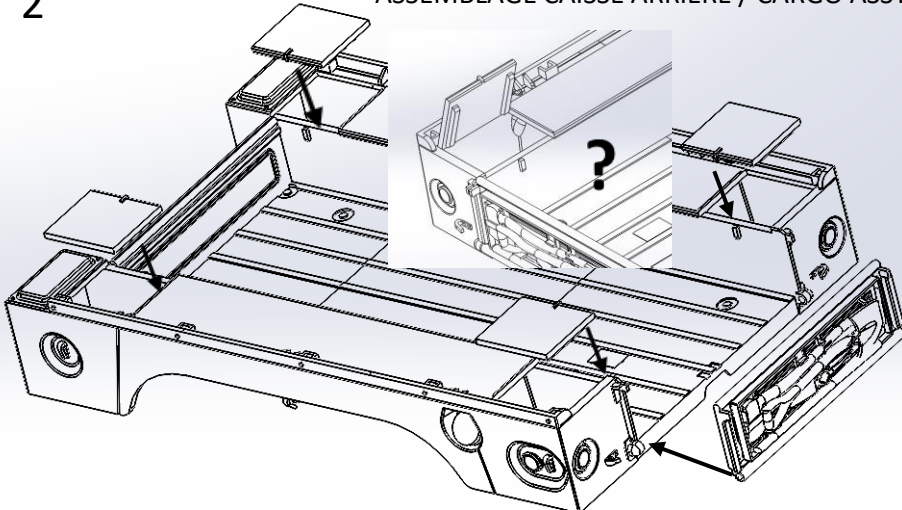
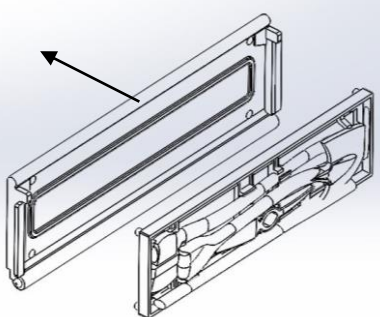

3

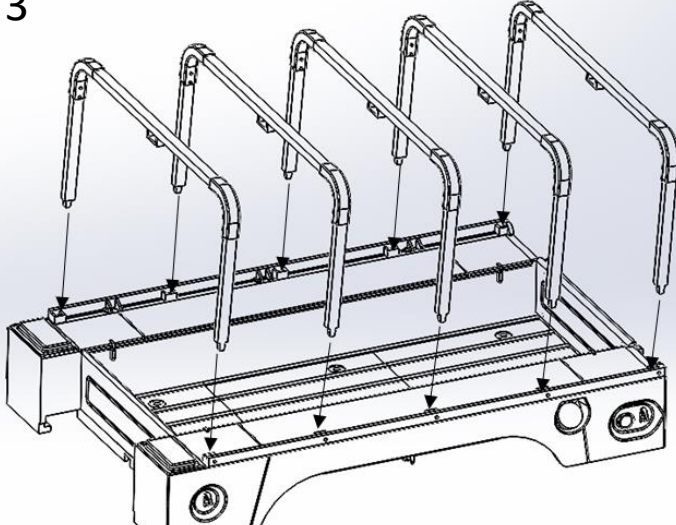

4

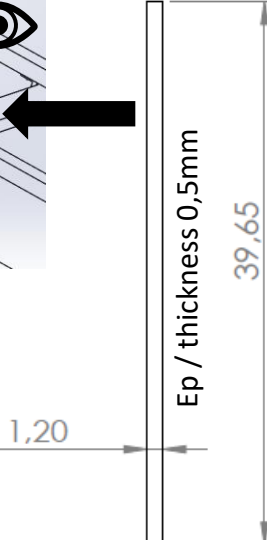
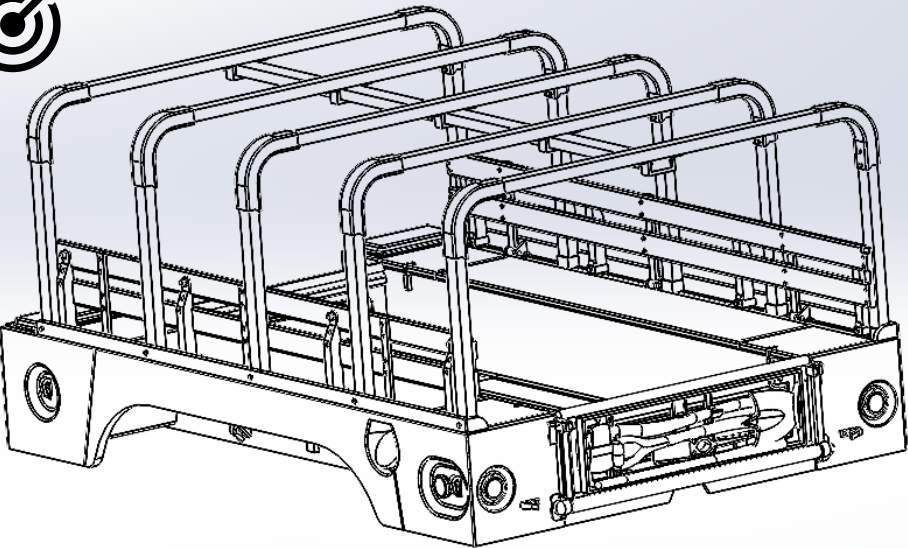
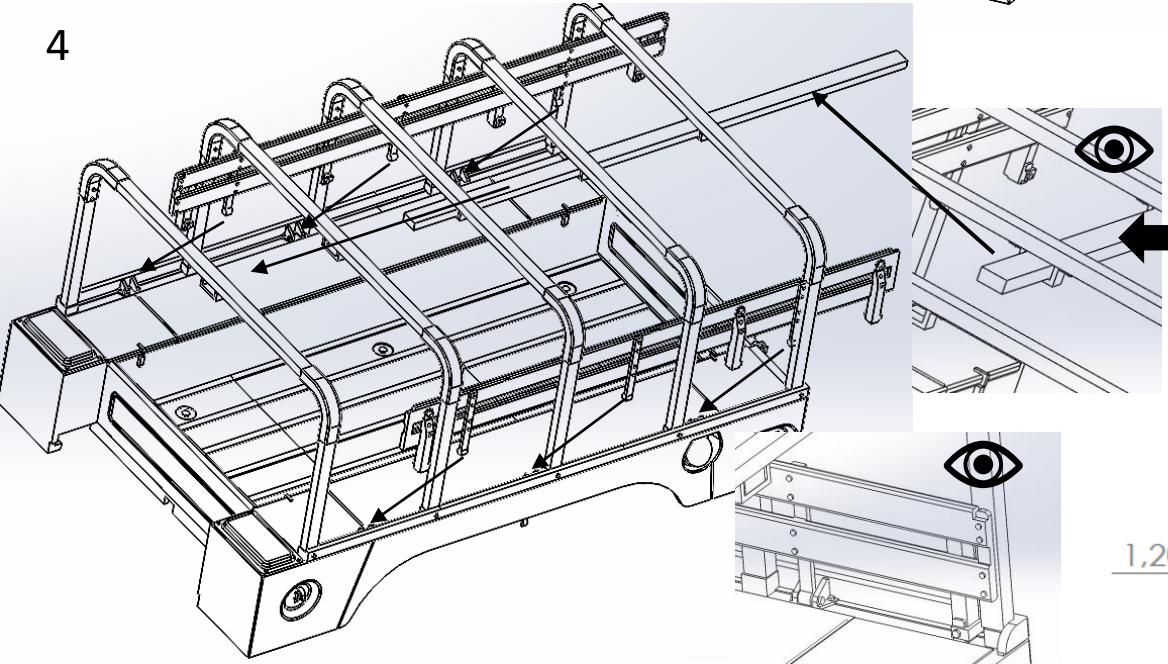

## 13 assemblage final / final assy

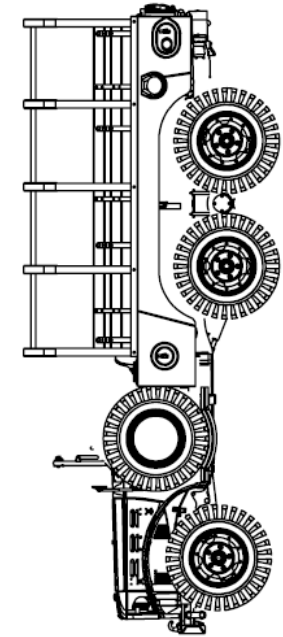
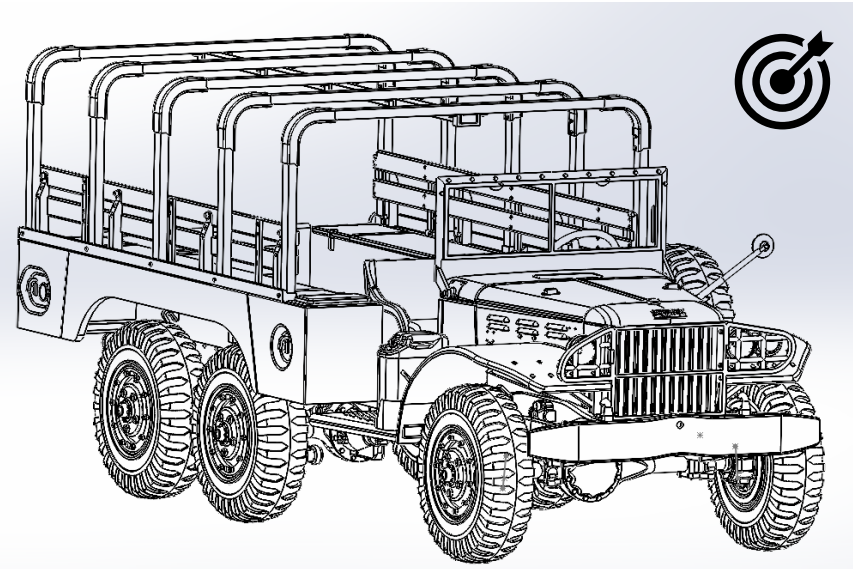
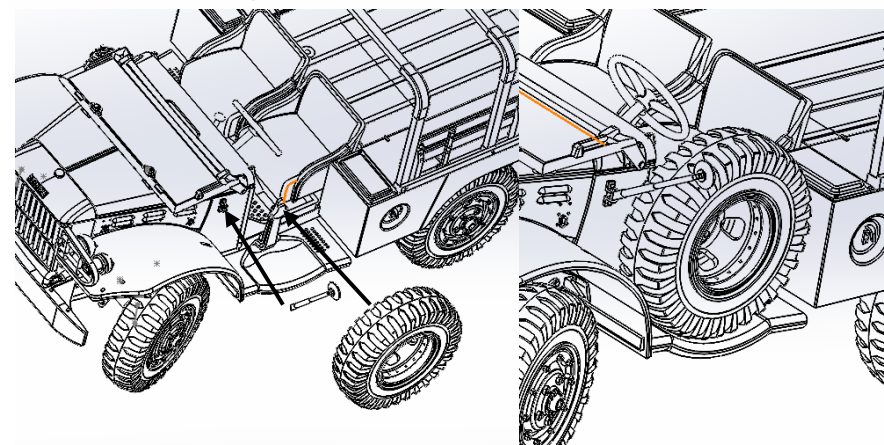
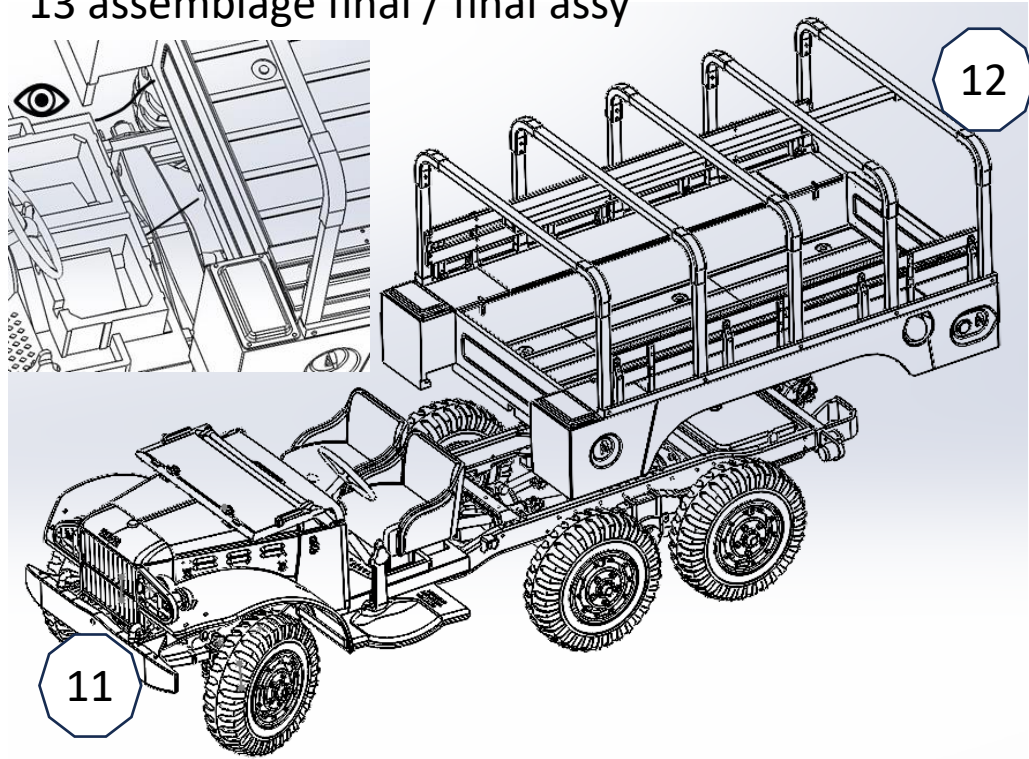

**Vous êtes arrivés à la fin du montage, Bravo! Au suivant...**  
**You succeeded this kit assembly. Cheers! Next please...**

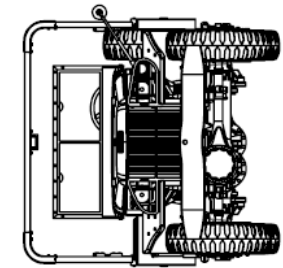
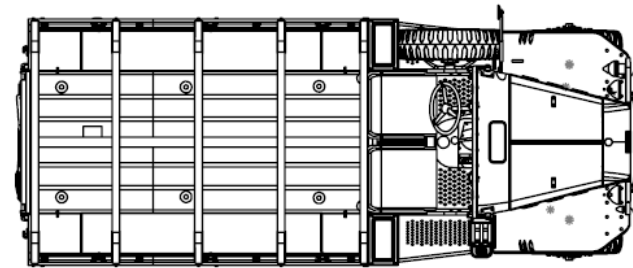

Couleur générale du véhicule, VERT OLIVE DRAB., JAUNE sur les aérodromes. NEUTRAL GRAY pour l'US NAVY.  
Certaines pièces optionnelles comme les crochets de halage, moufles n'apparaissent pas dans la notice.  
Consultez les documentations existantes, photos de terrain ou certains forum maquettistes pour quelques idées d'emploi.

General colour is US OLIVE DRAB, on airfields vehicles are painted in YELLOW and NEUTRAL GRAY for the navy.  
Some parts furnished on plates are not seen in this present notice as hooks and towing cables.  
Please refer to internet or documentation for further situation ideas .

### English captions, to read before you start!

This model is an original creation made from the available documentation which are the original technical instructions (TM), the manufacturers' dimensions, but also all the photo documents collected by the modelers and contributors to the MINITRACKS forum. Without all these enthusiasts, this model would never have seen the light of day. They were able to control and then validate each step of the 500 hours and more of the design of the model, participate in correcting the errors, for which they are all thanked here.

All parts are printed in acrylic resin and not in "Morbier"\*. Some parts have to be made yourself, it's hard, but that's how it is. Dimensional plans are provided as well as certain details from the original instructions. If parts are deformed, soaking them in a little hot water will help straighten them.

#### **Separation and preparation of parts:**

separate the parts with a fine saw, a pair of electronics pliers or a model maker's cutter. remove the rest of the construction legs from the part with scalpels or files.

Sand if necessary at the location of the connections. wash with soapy water and rinse the parts before assembly.

**Bonding of parts:** acrylic resins bond very well with a good cyanoacrylate glue. the use of "Cancoillotte"\*\*\* is possible but not recommended.

#### **you already knew it but:**

Don't put it in the hands of kids, equip yourself with 10 fingers two good eyes and patience. If you spend your days playing the jackhammer or suffer from Parkinson's disease, this model is not for you. Prefer construction games based on plastic bricks or find your calm by drinking a good "MACVIN"\*\*\* ...

(\*excellent French cheese from Jura)

(\*\*very very very very good and renowned Franc-Comtois cheese also called "glue")

(\*\*\*local medication based on white wine)

Creation design and production in Besançon, Franche Comté, France.

Contact: l.diemunsch@free.fr

Contact me to discover more products

### **Quelques conseils/some recommendations:**

(pour les moustachus et les autres /for the big moustache and the others too)

Cette nouvelle manière de créer des modèles originaux par impression 3D peut très largement dérouter les maquettistes qui sont habitués aux pièces en plastique à séparer de leur support. Ici, le principe reste le même mais requiert parfois plus d'attention et c'est le cas ici. Le tout est de commencer **par le haut** de la pièce en utilisant soit une pince coupante, soit un cutter ou un scalpel de maquettiste. Ces quelques schémas vont vous mettre sur la voie des bonnes pratiques.

This new way of creating original models by 3D printing can greatly confuse modelers who are used to plastic parts having to be separated from their support. Here, the principle remains the same but sometimes requires more attention and this is the case here. The key is to start at the **top of the part** using either cutting pliers, a cutter or a modeler's scalpel.

These few diagrams will put you on the path to good practices.

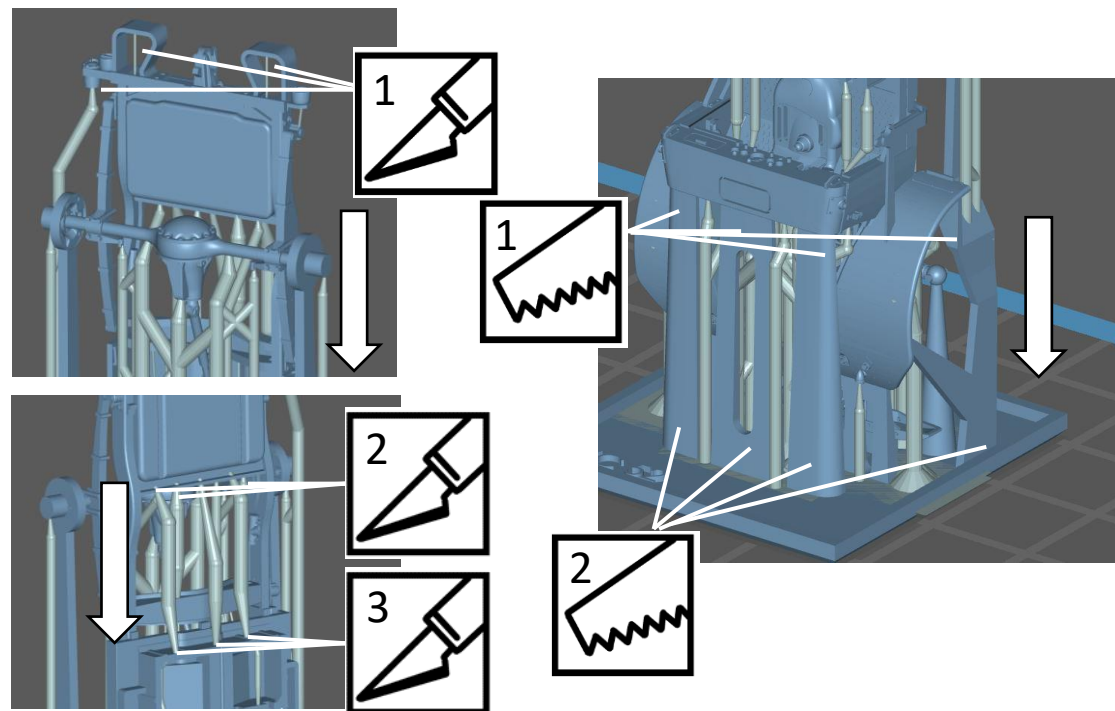

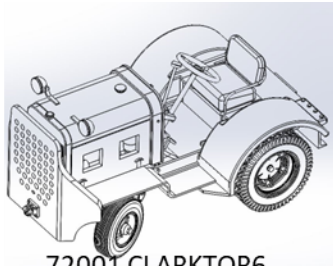

72001 CLARKTOR6

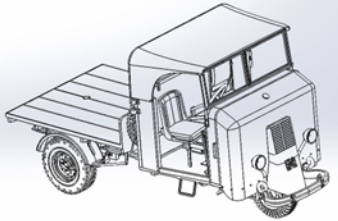

72002 TRACTEUR FAR CM86

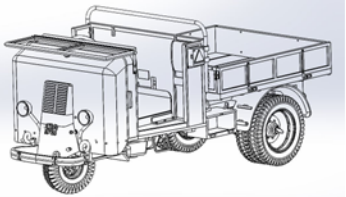

72003 TRACTEUR FAR CM86A



72012 Bidons eau US US Water can 30 pcs



72010 Bidons essence WH Jerrycans WH 30 pcs

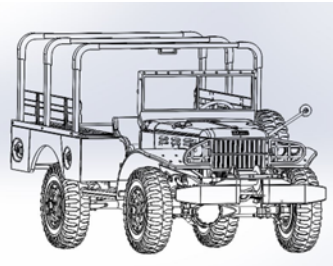

72521 72522 72523 DODGE WC 52

3 versions Early Mid Late + de 50 pièces à monter More than 50 parts to assemble

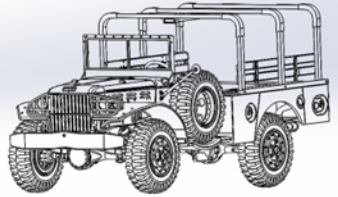

72511 72512 72513 DODGE WC 51

3 versions Early Mid Late + de 50 pièces à monter More than 50 parts to assemble

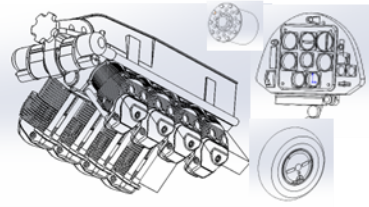

72014 MS 500 CRIQUET Moteur AS10C TDB et roues

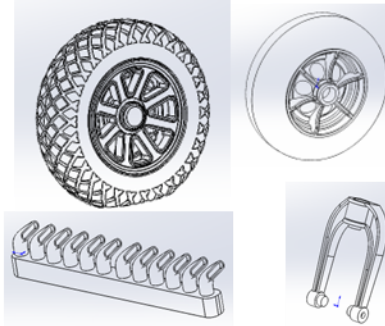

72015 P63C Roues fourche avant échappements

72017 US tool rack 4 racks pleins 1 rack vide et outils séparés 4 racks and an empty one with separate tools

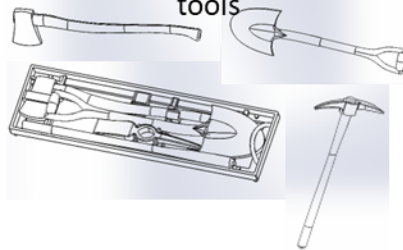

Il y a encore plein de références à découvrir dans la gamme AZUR ET OR Cockpits, équipements aéronautiques, sets de détaillage, accessoires. Catalogue sur demande.

De nombreuses nouveautés vont arriver en 2024!

Vous avez de la documentation? Je sais tenir un crayon! Créons ensemble de belles maquettes, justes et détaillées.

Contact: [l.diemunsch@free.fr](mailto:l.diemunsch@free.fr)

There is much more references to discover in AZUR ET OR brand Please contact by mail if intersted to receive the catalogue. Many new kits will be released in 2024!



### 72007 SE 535 MISTRAL 1/72 ème LA TOTALE!

Avec roues volets et roquettes

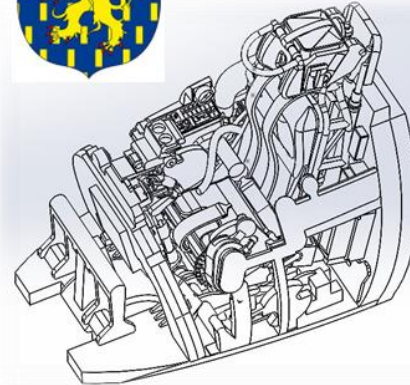

Coming March 2024: DODGE 6x6 WC 62 /63